

PROPRIETARY AND CONFIDENTIAL
 THE INFORMATION CONTAINED IN THIS DRAWING IS THE SOLE PROPERTY OF STAR INDUSTRIES. ANY REPRODUCTION IN PART OR AS A WHOLE WITHOUT THE WRITTEN PERMISSION OF STAR INDUSTRIES IS PROHIBITED.

UNLESS OTHERWISE SPECIFIED:
 DIMENSIONS ARE IN INCHES
 TOLERANCES: $\pm 1/16$
 FRACTIONAL \pm
 ANGULAR: MACH \pm BEND \pm
 TWO PLACE DECIMAL \pm
 THREE PLACE DECIMAL \pm

INTERPRET GEOMETRIC TOLERANCING PER:
 MATERIAL REFER PARTS DETAILS
 FINISH
 DO NOT SCALE DRAWING

	NAME	DATE
DRAWN	HI-TECH	8/7/2019
CHECKED	XX	XX/XX/XXXX
ENG APPR.		
MFG APPR.		
Q.A.		

COMMENTS:

 STAR INDUSTRIES		
TITLE: MODEL 1575 3/4 CYD. CONCRETE HOPPER		
SIZE A	DWG. NO. 1575 CONC HOPPER - DLR	REV 0
SCALE: 1:20	WEIGHT: 720.06 LBS	SHEET 1 OF 2

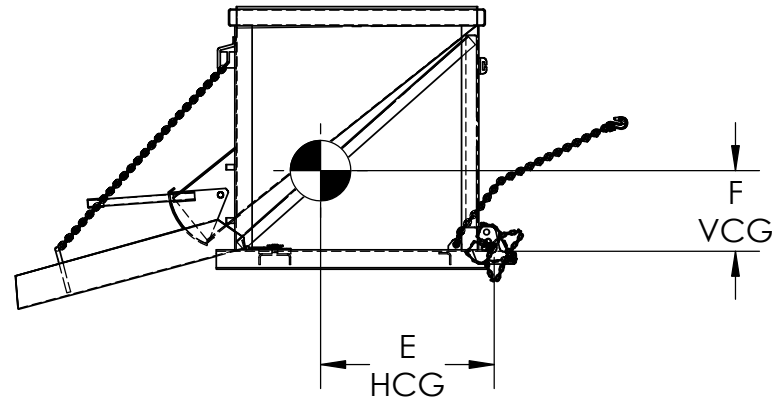
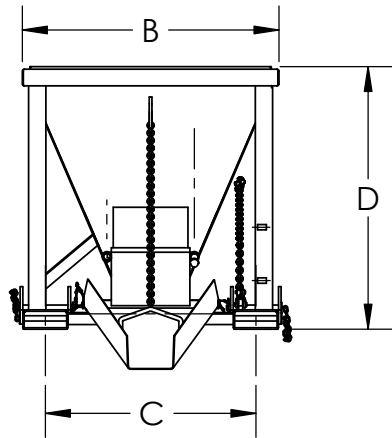
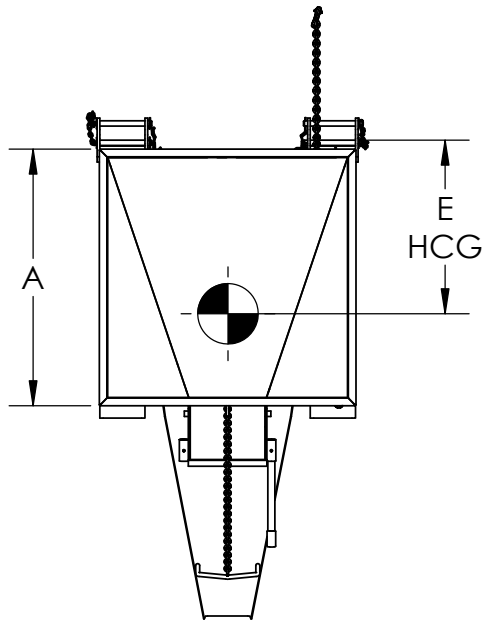

1575 CONCRETE HOPPER:-

- Rated Capacity 3/4" CYD. (actual struck cap - 21.72 cft.)
- 30" Swivel Chute - Swings 60 degrees - chain permits adjusting angle of chute.
- Fork Pockets accepts forks up to 7" wide and up to 2.5" thick.
- Designed for use with 48" long forks - longer forks can be used however they will protrude out front of hopper which may create a safety hazard.
- Welded all steel construction -hopper shell 10 ga, structure 1/4" plate.
- Empty Weight - 720 lbs.

NOTE: Fully loaded hopper requires a minimum lift capacity of 5,027 lbs. based on a concrete weight not to exceed 145 cft. When using a telehandler make sure the boom is kept in a 5,100 lb or greater lift capacity range.

Model Numbers	A	B	C	D	E	F	CAPACITY	EMPTY	LOADED HORZ CG	LOADED VERT CG
1575 Concrete Hopper	48 1/8"	48 1/8"	39 1/2"	49 3/8"	32 9/16"	15 1/8"	3/4" CYD	720 LBS	31 3/16"	30 7/8"

SIZE A	DWG. NO. 1575 CONC HOPPER - DLR	REV 0
SCALE: NTS	WEIGHT: 720.06 LBS	SHEET 2 OF 2