

PROPRIETARY AND CONFIDENTIAL
 THE INFORMATION CONTAINED IN THIS DRAWING IS THE SOLE PROPERTY OF <INSERT COMPANY NAME HERE>. ANY REPRODUCTION IN PART OR AS A WHOLE WITHOUT THE WRITTEN PERMISSION OF <INSERT COMPANY NAME HERE> IS PROHIBITED.

		UNLESS OTHERWISE SPECIFIED:		NAME	DATE
		DIMENSIONS ARE IN INCHES	DRAWN	PK	2/12/20
		TOLERANCES:	CHECKED		
		FRACTIONAL ±	ENG APPR.		
		ANGULAR: MACH ± BEND ±	MFG APPR.		
		TWO PLACE DECIMAL ±	Q.A.		
		THREE PLACE DECIMAL ±	COMMENTS:		
		INTERPRET GEOMETRIC TOLERANCING PER:			
		MATERIAL			
NEXT ASSY	USED ON	FINISH			
APPLICATION		DO NOT SCALE DRAWING			

STAR INDUSTRIES		
TITLE: MODEL 160A-18 SGL SIDE DROP N GO AUGER PALLET		
SIZE A	DWG. NO. 160A-18 DLR DWG	REV
SCALE: 1:32	WEIGHT: 425 LBS.	SHEET 1 OF 2

5

4

3

2

1

MODEL 160A-18 SINGLE SIDE "DROP n GO" AUGER PALLET

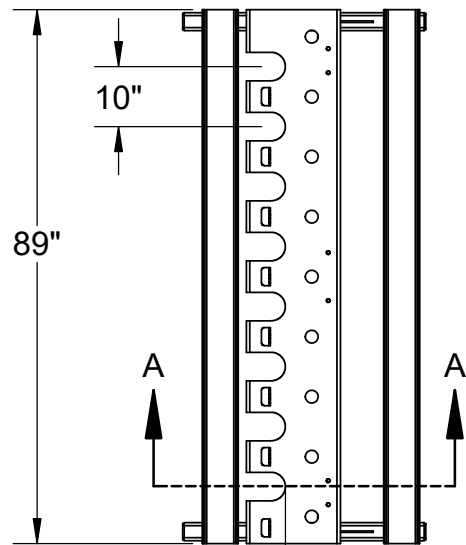

- Unique design permits placement of augers directly from your skid-steer or mini excavator.
- Eliminates manual handling - a real plus with the larger augers weighing up to 400 lbs. or more.
- Keeps augers organized and helps protect them from damage
- Accommodates up to 8 augers depending on size.
- Loaded pallet can be moved with forklift. Safety chain (not shown but included) secures augers to pallet.
- Bolt-on Top is replaceable in the unlikely event it is damaged.
- Single side design saves valuable yard space.

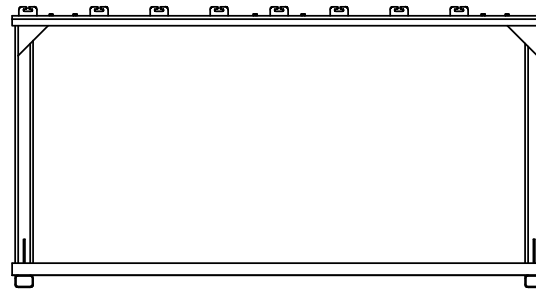
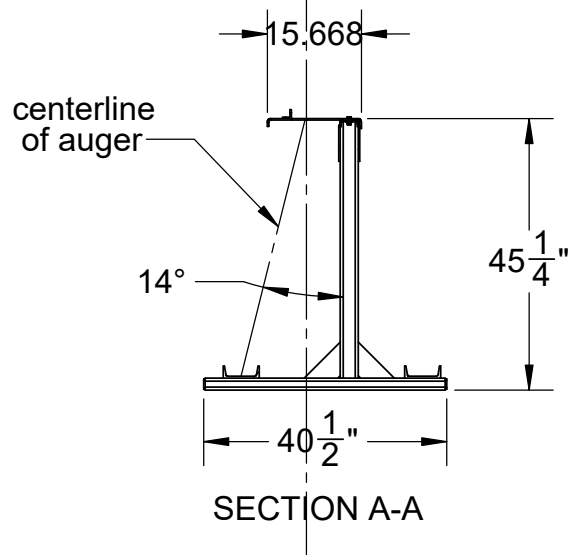

SIZE A	DWG. NO. 160A-18 DLR DWG	REV
SCALE: 1:32	WEIGHT:	SHEET 2 OF 2